

LCT-FGO

# DANUBIO

FrigoCarbonatore con Sistema ad Osmosi Inversa

*Water Cooler & Carbonating system with Reverse Osmosis*



**CAPACITÀ  
CARBONATORE**

**CARBONATING  
CAPACITY**

**2,5 |**



**EROGATORE D'ACQUA OSMOTIZZATA  
FREDDA, FREDDA FRIZZANTE E  
TEMPERATURA AMBIENTE**

***OSMOTIC WATER DISPENSER FOR COOL  
STILL, COOL SPARKLING AND ROOM-  
TEMPERATURE WATER***



## CARATTERISTICHE TECNICHE



LCT-FG0

### Sezione FrigoCarbonatore:

Capacità carbonatore	2,50 l (1,5 l erogata)
Alimentazione	220 V 50 Hz
Gas	R134A a norma CFC
Compressore	1/1 Hp ermetico
Raffreddamento	sistema di refrigerazione del gas R134 a liquido, refrigerazione acqua erogata banco a secco

### Sezione Osmosi Inversa:

**VERSIONE 60 l/h**

**VERSIONE 90 l/h**

Motore	180 W - 220 V - 50 Hz raffreddamento a liquido	
Pompa	rotativa a palette capacità 200 l/h 300 l/h	
Membrane Osmotiche	n° 2 1812 da 100 GPD TFC	n° 2 2012 da 150 GPD TFC
	(Thin Film Composite) by FilmTec	
Filtro	per sedimenti in-line da 12" - 5 micron	
Filtro	carbone attivo alimentare in-line da 12" - 5 micron	
Produzione acqua osmotizzata	60 l/h (+/- 10%)	90 l/h (+/- 10%)
Pressione d'esercizio	8 bar	
Pressione acqua in entrata	min 2 bar - max 5 bar	
Sistema di controllo	centralina di controllo con sistema anti-allagamento	
Peso	28 kg	
Dimensioni	248 x 386 x 390 mm (L-H-P)	

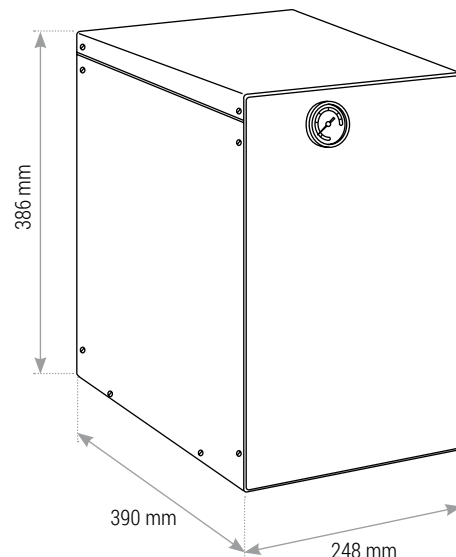

## TECHNICAL FEATURES



### Water Cooler and carbonating section:

Carbonating capacity	2.50 l (1,5 l delivered)
Power supply	220 V 50 Hz
Gas	R134a in accordance with CFC
Compressor	1/1 Hp sealed
Cooling	refrigeration system of gas R134 liquid, dispensed water cooling dry bank

### Reverse Osmosis Section:

**VERSION 60 l/h**

**VERSION 90 l/h**

Engine	180W - 220V - 50Hz water-cooled	
Pump	Rotary vane capacity 200 l/h 300 l/h	
Osmotic membrane	n° 2 1812 from 100 GPD TFC	n° 2 2012 from 150 GPD TFC
	(Thin Film Composite) by FilmTec	
Filter	sediment in-line 12" - 5 micron	
Filter	activated carbon for food-use in-line 12" - 5 micron	
Osmotic Water production	60 l/h (+/- 10%)	90 l/h (+/- 10%)
Working pressure	8 bar	
Incoming water pressure	min 2 bar - max 5 bar	
Control system	control unit with anti-flooding system	
Weight	28 kg	
Dimensions	248 x 386 x 390 mm (L-H-D)	

## ACCESSORI OPZIONALI

OPTIONAL ACCESSORIES



RUBINETTO - FAUCET  
3 acque  
3 water



RUBINETTO - FAUCET  
Monocomando - a 5 vie - canna bassa  
Single-control - Five-way mixer tap - low cane



RUBINETTO - FAUCET  
Monocomando - a 5 vie - canna alta  
Single-control - Five-way mixer tap - high cane

## ACCESSORI IN DOTAZIONE

SUPPLIED ACCESSORIES



Kit di installazione  
Installation Kit

## ACCESSORI NECESSARI

ACCESSORIES REQUIRED



Riduttore per bombole  
ricaricabili con manometro  
di bassa pressione assiale  
Reducer for rechargeable  
gas cylinders with axial low  
pressure gauge



RUBINETTO - FAUCET



BOMBOLE 1-2-4 Kg  
Ricaricabile  
CO2 Gas cylinder  
1-2-4 Kg Rechargeable

La Commercè ha scelto la qualità  
dei raccordi ad innesto rapido di  
La Commercè has chosen the  
quality of John Guest push-in fittings

**John Guest**